



Suite 100 – 3313 32nd Ave. Vernon, BC V1T 2M7
P:250-542-8085 F:250-542-5236 www.mqn.ca

ADDENDUM NO.3

Project: Vernon and District Performing Arts Centre
Lobby Bar & Kitchen Renovation
Owner: RDNO
Tender No: TDR#2016-P01
MQNi No: 15924i
Date: February 25th 2016

TO ALL PROPOSERS

GENERAL:

- This addendum is issued prior to tender closing to provide for certain revisions as noted herein.
 - All such revisions will become part of the Contract and the effects shall be reflected as required in the Bid Form.
 - All work shall be performed in accordance with the Contract Documents.
-

1.0 INTERIOR DESIGN:

1.1 GENERAL:

- 1.1.1 Refer to Tender Document D, Page 3
Replace previous page 3 with new page 3 enclosed as an attachment in Addendum No.3
- 1.1.2 Upon tender close date, RDNO plans to review the submissions the week of February 29th 2016 and award the project by Monday March 7th 2016 so GC's can ensure adequate notice to millwork trades.

1.2 DRAWINGS:

- 1.2.1 Drawing ID202 – Main Floor Construction Plan
Refer to Equipment Type E1
Revise to read as follows;
'New dishwasher **S&I by GC**. Hobart/LXGeR Tall/ 23-15/16"W x 26-13/16"D x 41-7/16"H'
- 1.2.2 Drawing ID202 – Main Floor Construction Plan
Refer to Equipment Type E4
Revise to read as follows;
'New under counter freezer **S&I by GC**. Delfield/ UC4560N/ 60.13"W x 31.5"D x 34.25"H'
- 1.2.3 Refer to the attached SK#01 - TYP. SS-1 Bar Countertops Detail
Note the SS-1 thicknesses, edging details, substrates and edge profile details for the rounded and straight raised solid surface countertops

End of Addendum

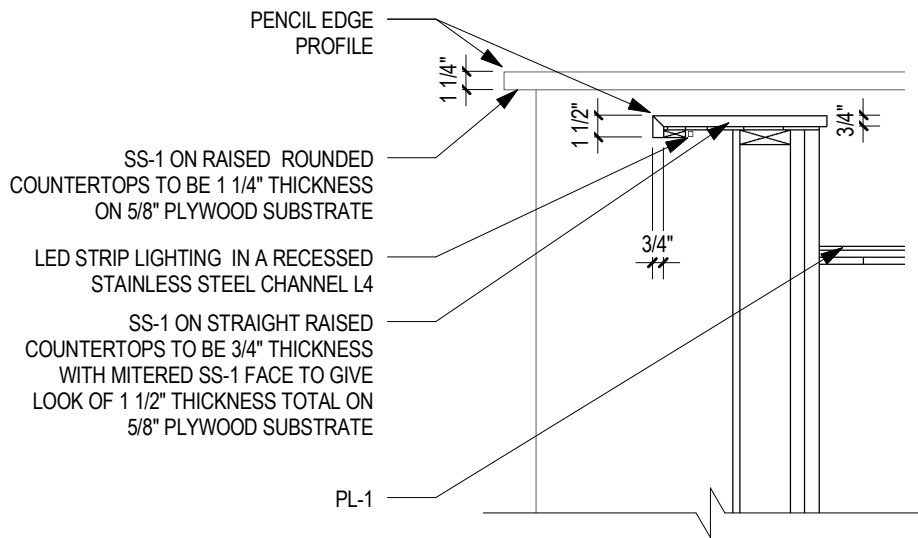

1 ADD#03_SK#01_TYP. SS-1 BAR COUNTERTOPS DETAIL
 ID901 SCALE: 1" = 1'-0"



PROJ. TITLE VERNON PERFORMING ARTS CENTRE LOBBY RENOVATION

DWG. TITLE TDR#2016-P01 ADDENDUM #03

#100 – 3313 32nd Ave, Vernon, BC V1T 2M7
 T: 250-542-1199 www.mqnarchitects.com

| NO. | REV. | ISSUE | YYYY/MM/DD |
|-----|------|---------------------|------------|
| 1 | | ISSUED FOR ADDENDUM | 02/23/2016 |
| | | | |
| | | | |

DRAWING: SK#01 PROJECT: 15924i SCALE: 1" = 1'-0" DRAWN BY: DL

I/We hereby certify that I/We have read and fully understand the Tender Form, Tender Terms, Project Terms, Specifications, and all other documents, instructions, forms, and terms comprising the Tender Documents for this Project, and make the following offer:

| | |
|-----------------------|-----------------|
| | \$ _____ |
| | \$ _____ |
| SUBTOTAL | \$ _____ |
| GST | \$ _____ |
| NET TOTAL COST | \$ _____ |

State earliest installation starting date: _____

State number of actual calendar days to complete proposed work: _____

State warranty: _____

State regular hours of business: _____

State telephone number during regular business hours: _____

State telephone number outside regular business hours: _____

Name of contact: _____

Number of employees currently on staff: _____

State base location of maintenance/service staff: _____

